

Automation Catalogue



STRENGTH THROUGH COOPERATION

Column & Booms



CaB Systems

Cost efficient and flexible weld mechanization

- Modular design concept allows total customization using standard components.
- Large selection of available components to integrate for a custom solution:
 - Any A2 or A6 weld head
 - A2-A6 Process Controller PEK with ESAB DC or AC power sources
 - ESAB turning rolls and positioners
 - ESAB flux feeding and recovery systems
 - Monitoring systems and cameras
 - Four basic station configurations, suitable for most standard applications.
- Three different sizes; 300, 460 and 600 (number refers to boom profile height (mm) which determines working range and load capability).
- Choose from stationary or mobile, rail-travelling carriage systems.
- Versatile to respond to any automated welding demand.



Standard CaB sizes

The three different sizes 300, 460 and 600 are the beam height dimensions of the boom in millimeters. Each boom size has a corresponding column. The different sizes are not only limited in where it can fit, but also how far the boom can extend and how much load that can be put on.

CaB 300S / 460S

Standard format - exceptional economy

- Conventional column and boom with a movable boom and the welding head mounted at the end of the boom.
- Standard mechanical performance, with cable support.
- Options like camera system, pulse encoder-regulated speed and flux control.
- The CaB 300S have a working range of 3 to 5 m (10 to 16.5 ft.) both vertically and horizontally.
- The CaB 460S have a working range of 5 to 7 m (16.5 to 23 ft.) both vertically and horizontally.



Basic Station 1 - Standard format

Conventional Column and boom, with a movable boom and welding head at boom end. Welding equipment can be positioned along four axes.

CaB Systems

Cont.

CaB 300M / 460M / 600M

Modular format - extended functionality

- A modular range of column and booms, available in three load sizes.
- Standard mechanical performance, including cable chains for the boom motions.
- The welding head is mounted at the front end of the boom.
- More than 20 options fully integrated, such as tandem welding, shift function, transport speed etc.
- Due to modularity and the fixed configuration possibilities the lead times for delivery can be kept at a minimum.

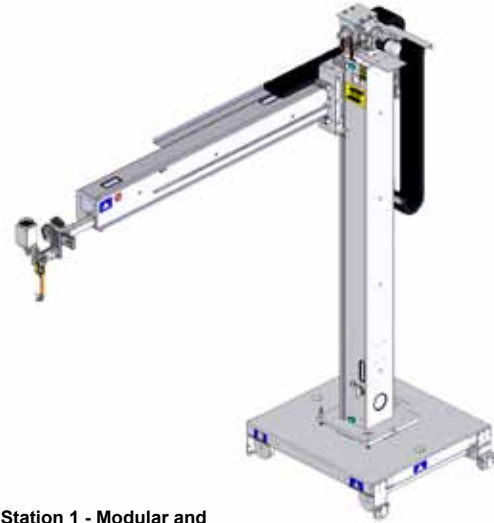

Basic Station 1 - Modular and Custom format

Conventional Column and boom, with a movable boom and welding head at boom end. Welding equipment can be positioned along four axes. Cable chains are included.

CaB 300C / 460C / 600C

Custom format - special capabilities

- A customized range of welding column and booms for different customer requirements and applications.
- Loading capacities and working strokes for utmost accessibility to the welding joints.
- Based on the modular CaB range, solutions to meet the most demanding request can be achieved.
- Welding methods as TIG, MIG and SAW cladding as well as Nar row Gap can be chosen on customized stations.



Basic Station 2 - Custom format

Conventional Column and boom, with a movable boom and welding head at boom end combined with a boom-carriage-mounted welding head (not CaB 300).

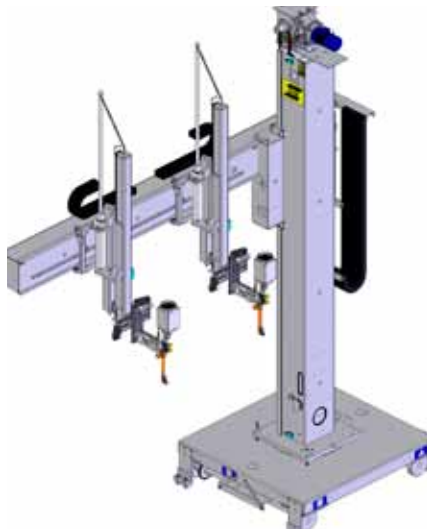

Basic Station 3 - Custom format

Side-boom manipulator with horizontally fixed boom, supporting one or two welding heads. This welding station, which offers flexible movement, is the basic unit for welding girders and profiles and for joining plates and sections.

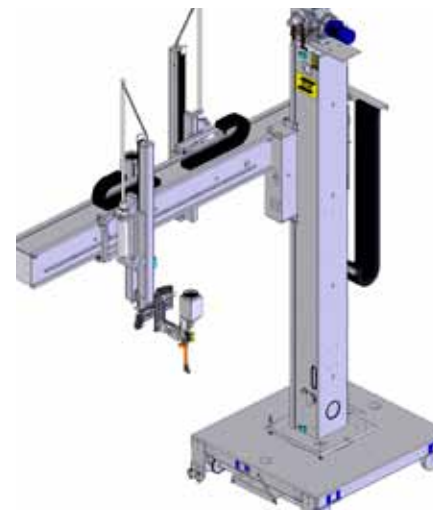

Basic Station 4 - Custom format

Side-boom manipulator with double-track boom. Welding heads mounted on either side of the boom. The boom carriages can be individually controlled by the joint tracking systems, on separate tracks. Ideal for transversal double-fillet welding of stiffeners.

CaB Systems

Technical data CaB 300S and CaB 300M

Technical data - Column		CaB 300S / 300M		
Effective working range, m (ft.)	3 (10)	4 (13)	5 (16.5)	
Max. boom height A , mm (ft.) using movable carriage, min mm (ft.)	4070 (13) 930 (3)	5070 (16.5) 930 (3)	6070 (20) 930 (3)	
Max. boom height B , mm (ft.) using concrete stand, min mm (ft.)	3955 (15.6) 815 (2.67)	4955 (19.5) 815 (2.67)	5955 (23.5) 815 (2.67)	
Max. boom height C , mm (ft.) using stationary foot plate, min mm (ft.)	3750 (14.7) 610 (2.4)	4750 (18.7) 610 (2.4)	5750 (22.6) 610 (2.4)	
Total height D using movable carriage, mm (ft.)	5170 (17)	6170 (20)	7170 (23.5)	
Total height E using concrete stand, mm (ft.)	5055 (16.5)	6055 (20)	7055 (23)	
Total height F using stationary foot plate, mm (ft.)	4850 (16)	5850 (19)	6850 (22.5)	
Lifting speed, m/min (ipm)	0.7 (27.5)	0.7 (27.5)	0.7 (27.5)	
Max total load on column platform, kg (lbs)	600 (1320)	600 (1320)	600 (1320)	

Technical data - Boom			
Extension G , max mm (ft.) min mm (ft.)	3580 (11.75) 540 (1.77)	4580 (15) 540 (1.77)	5580 (18) 540 (1.77)
Permissible loads: total, max kg (lbs.) one end, max kg (lbs.)	300 (660) 240 (530)	220 (485) 150 (330)	150 (330) 75 (165)
Cross-sectional diameter H , mm (ft.)	325 (13)	325 (13)	325 (13)
Welding speed, m/min (ipm)	0.1-2.0 (4-79)	0.1-2.0 (4-79)	0.1-2.0 (4-79)
Transport speed, m/min (ipm)	2.0 (79)	2.0 (79)	2.0 (79)

Technical data - Rail carriage	
Track width L , inside to inside, mm (in.)	1730 (68.11)
Width x length, mm (in.)	2060x2330 (81.1x91.7)
Height I , mm (in.)	365 (14.37)
Welding speed, m/min (ipm)	0.1-2.0 (4-79)
Transport speed, m/min (ipm)	2.0 (79)
Total weight, kg (lbs.)	1670 (3681)

Technical data - Concrete stand	
Width x length, mm (in.)	2060x2100 (81.1x82.7)
Height J , mm (in.)	250 (9.84)
Total weight, kg (lbs.)	1550 (3417)

Technical data - Foot plate	
Width x length, mm (in.)	1100x1100 (43.3x43.3)
Height K , mm (in.)	40 (1.57)
Total weight, kg (lbs.)	350 (772)

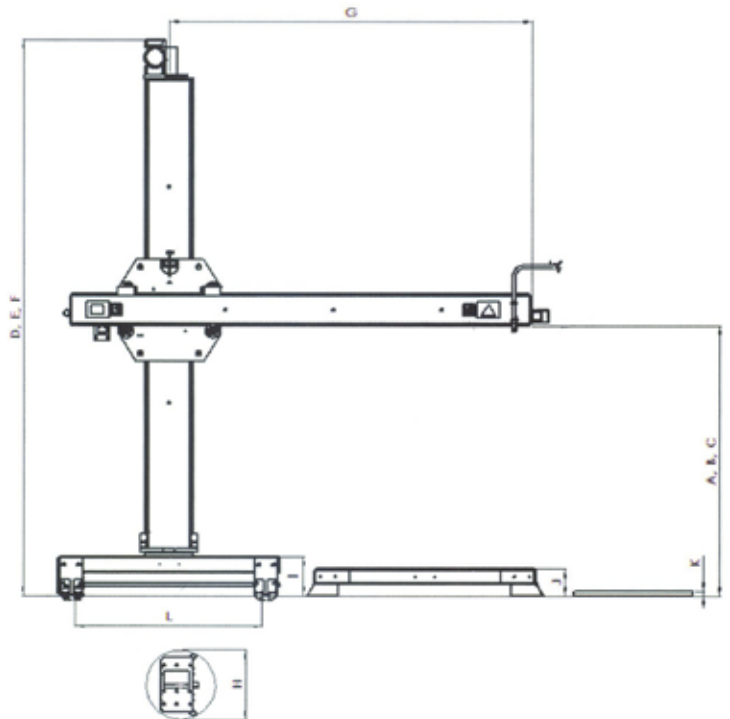

CaB Systems

Technical data CaB 460S and CaB 460M

Technical data - Column	CaB 460M only	CaB 460S CaB 460M	CaB 460S CaB 460M	CaB 460S CaB 460M
Effective working range, m (ft.)	4 (13)	5 (16.5)	6 (20)	7 (23)
Max. boom height A , mm (ft.) using movable carriage, min mm (ft.)	4950 (16) 950 (3.12)	5950 (19.5) 950 (3.12)	6950 (23) 950 (3.12)	7950 (26.08) 950 (3.12)
Max. boom height B , mm (ft.) using concrete stand, min mm (ft.)	4845 (16) 845 (2.77)	5845 (19) 845 (2.77)	6845 (22.5) 845 (2.77)	7845 (25.74) 845 (2.77)
Max. boom height C , mm (ft.) using stationary foot plate, min mm (ft.)	4510 (15) 510 (1.6)	5510 (18) 510 (1.6)	6510 (21.5) 510 (1.6)	7510 (24.64) 510 (1.6)
Total height D using movable carriage, mm (ft.)	6275 (20.5)	7275 (24)	8275 (27)	9275 (30.43)
Total height E using concrete stand, mm (ft.)	6170 (21)	7170 (23.5)	8170 (27)	9170 (30)
Total height F using stationary foot plate, mm (ft.)	5835 (20)	6835 (22.5)	7835 (25.5)	8835 (29)
Lifting speed, m/min (ipm)	2.0 (79)	2.0 (79)	2.0 (79)	2.0 (79)
Max total load on column platform, kg (lbs)	1500 (3300)	1500 (3300)	1500 (3300)	1500 (3300)

Technical data - Boom				
Extension G , max mm (ft.) min mm (ft.)	4715 (15.47) 715 (2.35)	5715 (18.75) 715 (2.35)	6715 (22.03) 715 (2.35)	7715 (25.31) 715 (2.35)
Permissible loads: total, max kg (lbs.) one end, max kg (lbs.)	1100 (2423) 550 (1211)	1050 (2313) 450 (1211)	1000 (2203) 350 (1211)	950 (2094) 150 (331)
Cross-sectional diameter H , mm (ft.)	630 (25)	630 (25)	630 (25)	630 (25)
Welding speed, m/min (ipm)	0.1-2.0 (4-79)	0.1-2.0 (4-79)	0.1-2.0 (4-79)	0.1-2.0 (4-79)
Transport speed, m/min (ipm)	2.0 (79)	2.0 (79)	2.0 (79)	2.0 (79)

Technical data - Rail carriage

Track width L , inside to inside, mm (in.)	1730 (68.11)
Width x length, mm (in.)	2100x2380 (82.7x93.7)
Height I , mm (in.)	485 (19.1)
Welding speed, m/min (ipm)	0.1-2.0 (4-79)
Transport speed, m/min (ipm)	2.0 (79)
Total weight, kg (lbs.)	2860 (6305)

Technical data - Concrete stand

Width x length, mm (in.)	2100x2410 (82.7x94.9)
Height J , mm (in.)	380 (14.96)
Total weight, kg (lbs.)	2900 (6393)

Technical data - Foot plate

Width x length, mm (in.)	1600x1600 (63x63)
Height K , mm (in.)	40 (1.57)
Total weight, kg (lbs.)	505 (1113)

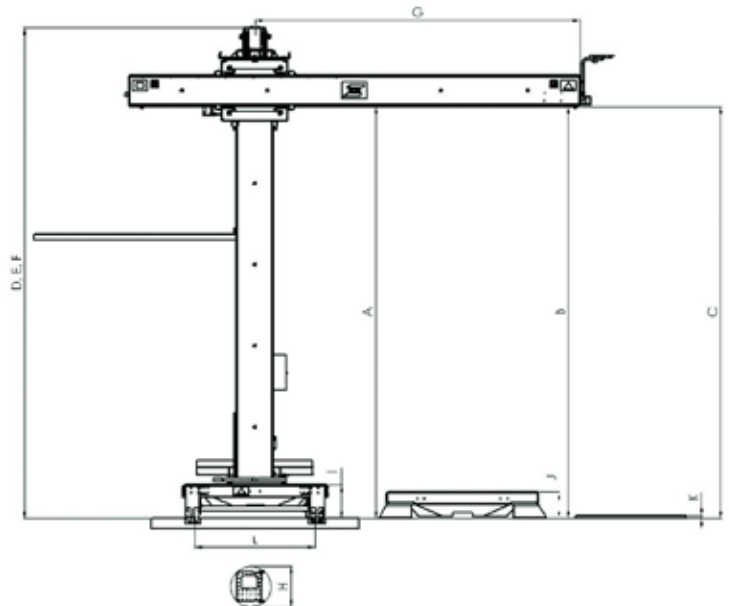

CaB Systems

Technical data CaB 600M

Technical data - Column		CaB 600M				
Effective working range, m (ft.)	6 (20)	7 (23)	8 (26)	9 (29.5)	10 (33)	
Max. boom height A , mm (ft.) using movable carriage, min mm (ft.)	7025 (276.6) 1075 (42.3)	8025 (316) 1075 (42.3)	9025 (355.3) 1075 (42.3)	10025 (395) 1075 (42.3)	11025 (434) 1075 (42.3)	
Max. boom height B , mm (ft.) using concrete stand, min mm (ft.)	6950 (22.8) 1000 (3.3)	7950 (26.1) 1000 (3.3)	8950 (29.4) 1000 (3.3)	9950 (32.6) 1000 (3.3)	10950 (35.9) 1000 (3.3)	
Max. boom height C , mm (ft.) using stationary foot plate, min mm (ft.)	8585 (28.2)	9585 (31.4)	10585 (34.7)	11585 (38)	12585 (41.3)	
Total height D using movable carriage, mm (ft.)	8510 (27.9)	9510 (31.2)	10510 (34.5)	11510 (37.8)	12510 (41)	
Lifting speed, m/min (ipm)	2.0 (79)	2.0 (79)	2.0 (79)	2.0 (79)	2.0 (79)	
Max total load on column platform, kg (lbs)						

Technical data - Boom

Extension E , max mm (ft.) min mm (ft.)	7000 (23) 1000 (3.3)	8000 (26) 1000 (3.3)	9000 (29.5) 1000 (3.3)
Permissible loads: total, max kg (lbs.) one end, max kg (lbs.)	1940 (4277) 550 (1213)	1830 (4034) 400 (882)	1700 (3748) 250 (551)
Cross-sectional diameter H , mm (ft.)	1000 (3.3)	1000 (3.3)	1000 (3.3)
Welding speed, m/min (ipm)	0.1-2.0 (4-79)	0.1-2.0 (4-79)	0.1-2.0 (4-79)
Transport speed, m/min (ipm)			
Total weight incl cables, kg (lbs.)	1050 (2315)	1165 (2568)	1280 (2822)

Technical data - Rail carriage 4WD

Track width L , inside to inside, mm (in.)	2500 (98.4)
Width x length, mm (in.)	3100x2600 (122x102)
Height I , mm (in.)	490 (19.3)
Welding speed, m/min (ipm)	0.1-2.0 (4-79)
Transport speed, m/min (ipm)	2.0 (79)
Total weight, kg (lbs.)	4800 (10582)

Technical data - Concrete stand

Width x length, mm (in.)	3100x2680 (122x105.5)
Height J , mm (in.)	415 (16.3)
Total weight, kg (lbs.)	4250 (9370)

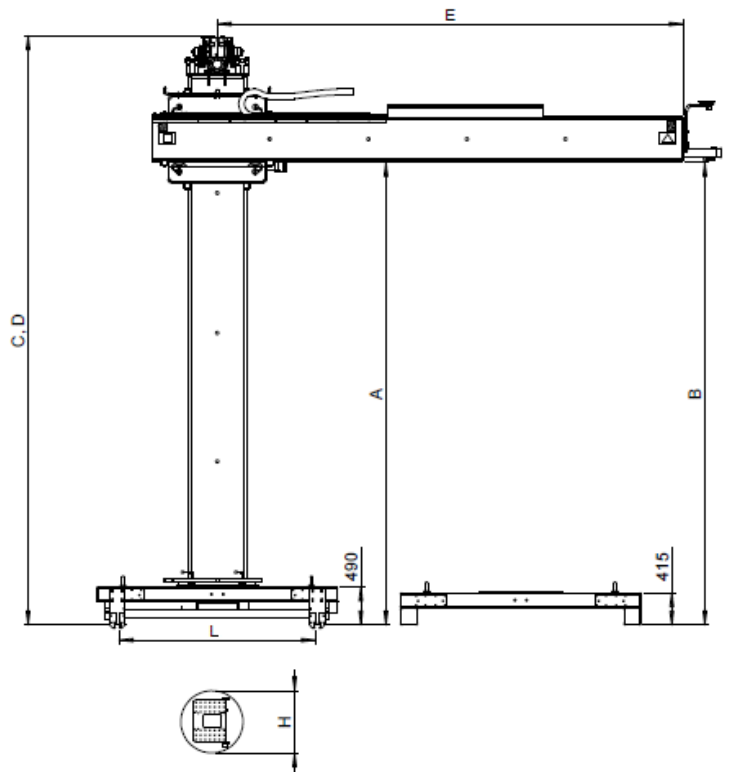

Cab 2200

For small and medium sized objects

- Designed for light duty.
- Smooth 360° lockable rotation.
- Linear guidings for smooth movement which makes it ideal for the gas metal arc welding (GMAW), gas tungsten arc welding (GTAW) and submerged arc welding (SAW) processes.
- Cable chain on column and boom.
- Movable carriage or fixed stand.
- IP 55 pendant control station using low voltage on the generous 10 m (33 ft.) cable.
- Anti-fall device and limit switches for all motions.
- Pay load of 70 kg (154 lbs.)



Ordering information

CaB 2200, manual carriage
 CaB 2200, fixed stand
 Sales Literature

0370 250 600
 0370 250 605
 XA00144220

Technical data

Mains supply, V	230/380/400/440
Frequency, Hz	50/60, 3-phase
Vertical speed, mm/min (ipm)	600 (23.6)
Boom speed, mm/min (ipm)	0-2050 (0-80.7)
Rotation	Manual
Electrical panel	IP55
Boom height max (a), mm (in.)	2500 (98.4)
Boom height min (a), mm (in.)	450 (17.7)
Boom height max (b), mm (in.)	2700 (106.3)
Boom extension max (c), mm (in.)	2500 (98.4)
Boom extension min (c), mm (in.)	490 (19.3)
Boom extension max (d), mm (in.)	2500 (98.4)
Boom extension min (d), mm (in.)	490 (19.3)
Wheel centre distance (e), mm (in.)	1600 (63)
Axle centre distance (f), mm (in.)	1500 (59)
Height of column (g), mm (in.)	3200 (126)

CaB 44, 55, 66 and 77

- Designed and robustly built to withstand rugged work environments.
- Smooth 360° lockable rotation.
- All vertical and horizontal guidings are precisely machined for smooth movement.
- Solid state inverter for variable speed of horizontal travel and travel carriage.
- Work gearbox for vertical travel via AC motor, complete with brake for added safety.
- High tensile roller chain used for vertical travel with the addition of a counter balance system with the column that provides smooth, effortless travel.
- IP 55 pendant control station using low voltage on the generous 10 m (33 ft.) cable.
- Anti-fall device and limit switches for all motions.
- Pay load of 420 kg (924 lbs.)



Ordering information

CaB 44, motorized carriage	0370 250 601
CaB 55, motorized carriage	0370 250 602
CaB 66, motorized carriage	0370 250 603
CaB 77, motorized carriage	0370 250 604
CaB 44, fixed stand	0370 250 606
CaB 55, fixed stand	0370 250 607
CaB 66, fixed stand	0370 250 608
CaB 77, fixed stand	0370 250 609
Sales Literature	XA00144120

Options & Accessories

Camera system	0370 250 616
Spools at rear end of the boom	0370 250 617
Motorized rotation	0370 250 618
Tandem platform	0370 250 619
0.5 m boom section	0370 250 621
0.5 m column section	0370 250 622

Technical data

Control voltage, V DC	42
Max ambient temperature	80°C (176°F)
Axial play, runner, mm (in.)	0.1 (0.004)
Max. torque-free load, kg (lbs.)	150 (330)



Telbo™ 6500 and Telbo™ 9500

Telescopic boom

- Save valuable workshop space with the unique 3-section telescope-like retraction of the boom, securing operator safety.
- Outstanding reach-out with heavy loading capacity to ensure superior productivity and weld quality.
- Ideal for internal/external circumferential welding of windtower applications.
- Flexible production, no matter if mixed sizes and plate thicknesses are to be welded - productive results are obvious.
- Loaded with 1000 kg (2204 lbs.) Flux BigBag and 1000 kg Wire EcoCoils, welding is continuously performed and costly dwell times are minimized.



Ordering information

For ordering information, please contact nearest ESAB representative.

Features

- PLC control system for synchronized boom motion
- Automatic "Wind Back" of wire during boom retraction
- Telescopic wire guides
- Remote controlled flux nozzle (option)
- Remote controlled height adjustm. of joint tracking sensor (option)
- Saving in factory-floor foot print
- Increased workshop safety
- Enables flexible production
- "Big Pack" handling concepts (option)
- Camera supervision system (option)

Applications

- Power generation, especially wind tower manufacturing lines.
- Pipeline, pipe mill contactors.
- General fabrication (small workshops with limited space).

Technical data	Telbo™ 6500	Telbo™ 9500
Effective work range, m (ft.)	6.5 (21.33)	9.5 (31.17)
Max extension, m (ft.) *)	8.0 (26.25)	12.5 (41)
Max load at boom end, kg (lbs.)	300 (661.4)	500 (1102)
Welding process	SAW / GMAW	SAW
Welding heads	A6	A6 SAW, Single/Tandem and Tandem/Twin
Control system	PLC / GMH	PLC / GMH
Operator seat	No	Yes

*) Measured from column centre.

