



**1. Gamme SENTINEL**

**2. Gamme F&G**

**3. Gamme Warrior**

**4. Système à adduction d'air**

# 1. GAMME DE CAGOULES SENTINEL

The word "SENTINEL" is written in a large, bold, yellow, stylized font. The letters are blocky with sharp, angular edges. A small "TM" trademark symbol is positioned at the top right of the final letter "L". The text is centered horizontally and set against a background of a bright, hazy sky over a dark, textured ground.

# SENTINEL™ A-50



# SENTINEL™

Conçu pour un large champ d'applications



# DESIGN BREVETÉ ESAB

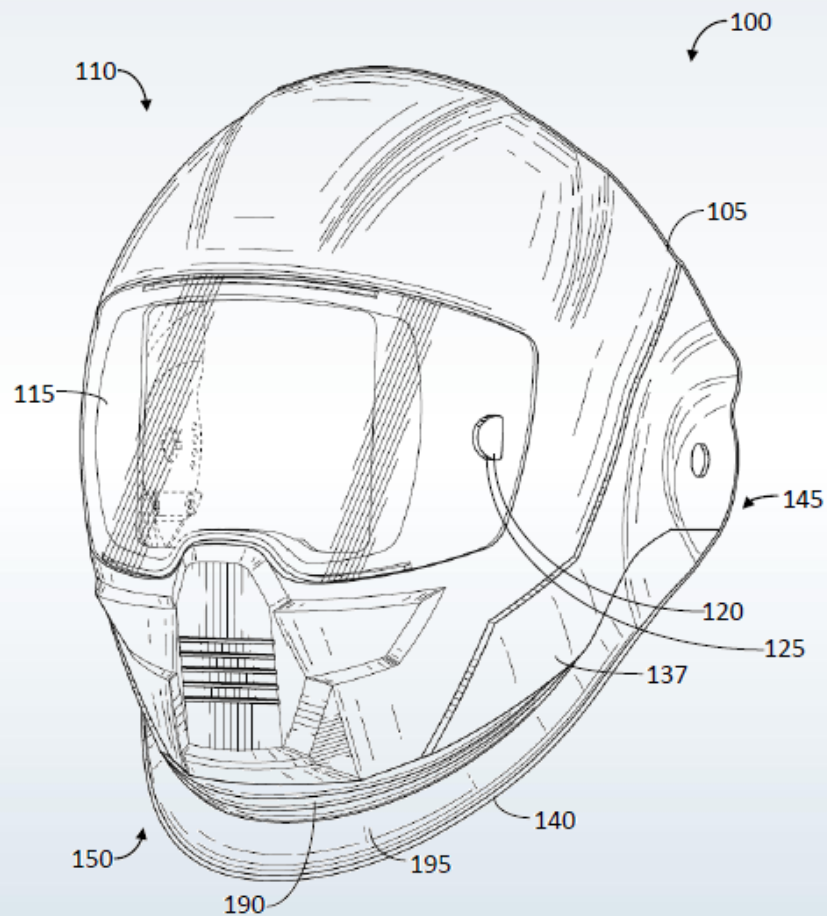



# SERRE-TÊTE HALO , AVEC MULTIPLES RÉGLAGES

- ✓ Serre-tête à 5 points, repartition poids parfaite
- ✓ Réglages sur 5 points
- ✓ Réglage longitudinal sur 4 points
- ✓ Réglage de l'inclinaison sur 4 points
- ✓ Bandeaux anti-transpirant avant et arrière confortable
- ✓ Coussin cranien à l'arrière
- ✓ Poids léger du matériau utilisé
- ✓ Amélioration de la qualité et robustesse

Vue avant



Vue derrière

# RÉGLAGES SERRE TÊTE EN DÉTAIL

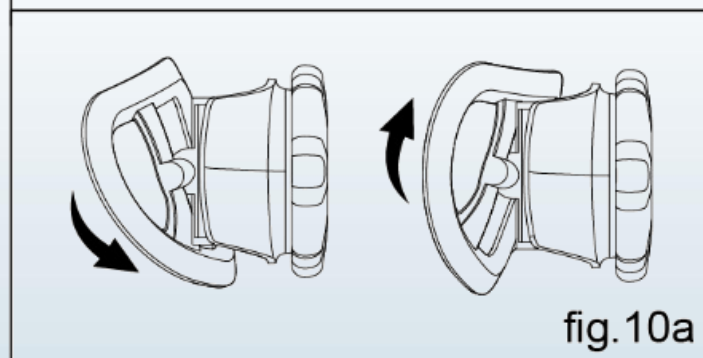
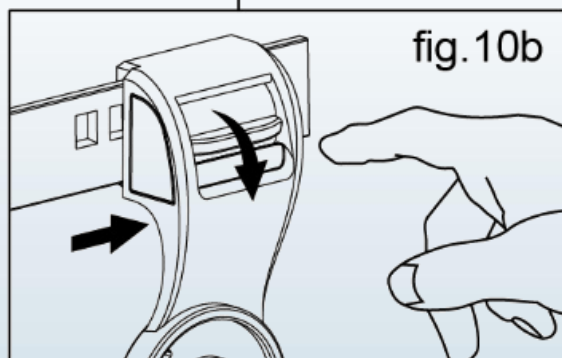
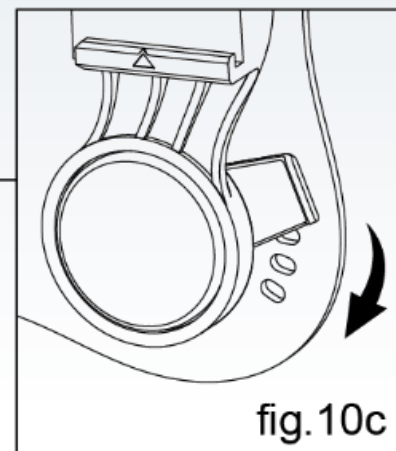
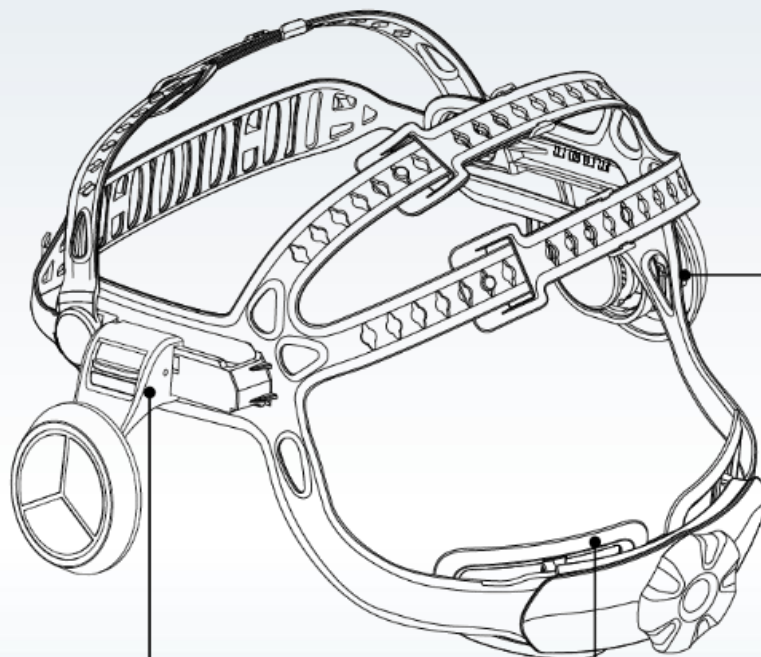



# FACILITÉ POUR REMPLACER DES PIÈCES D'USURE!

- ✓ Remplaçable en 10 seconds, sans enlever la cellule (front loaded)
- ✓ Niveau d'impact B – Très résistant
- ✓ Ecran ambre apporte plus de lumière
- ✓ Couche anti-rayure
- ✓ Options de de l'écran de protection: Claire et Jaune



Ecran clair

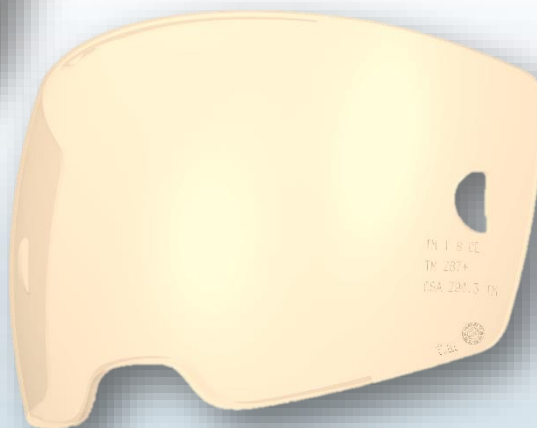

Ecran jaune



Fini les changements d'écran fastidieux

# REPLACEMENT DE L'ECRAN EXTÉRIEUR

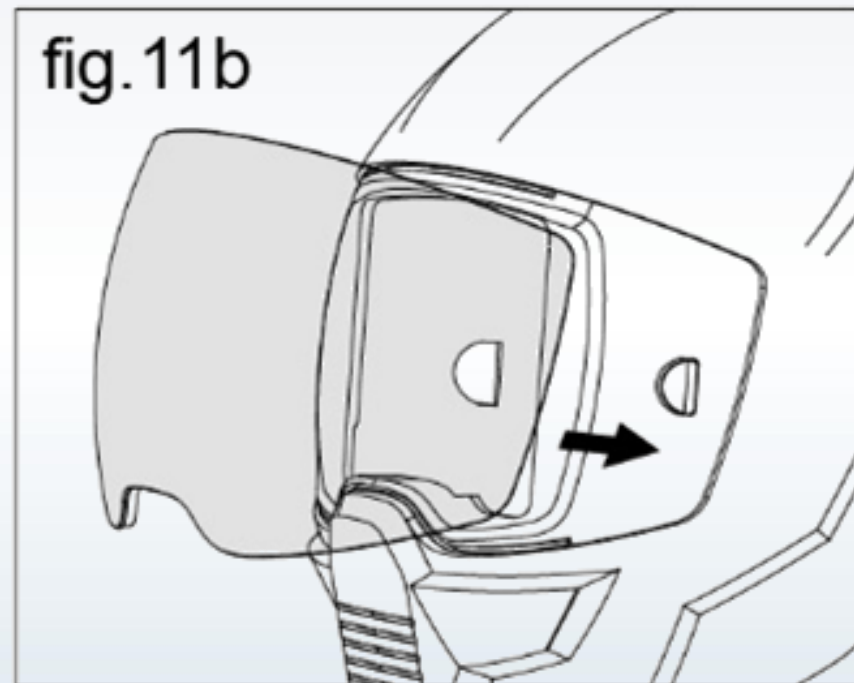
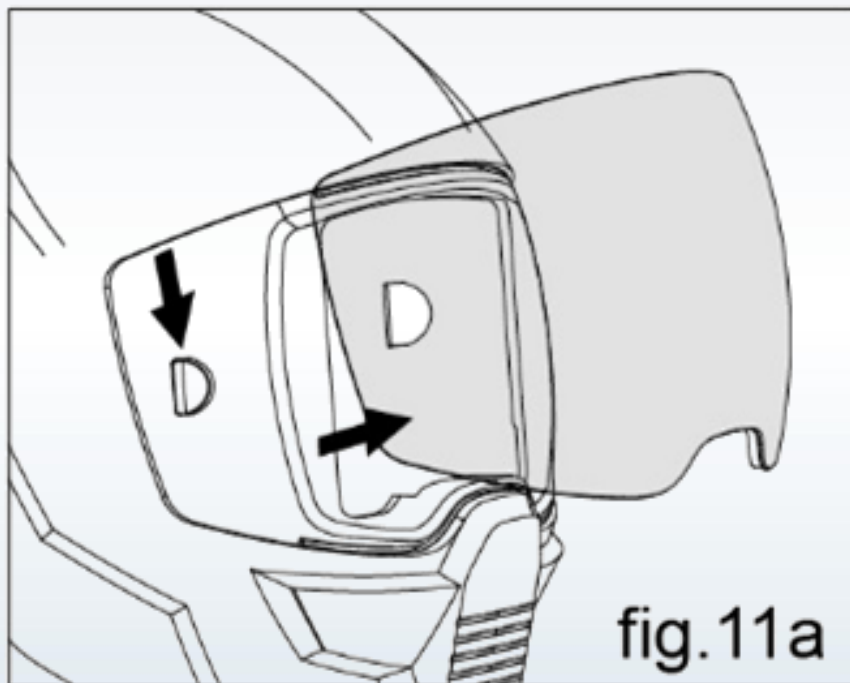

# PIÈCES D'USURE FACILE À RETROUVER: AUTOCOLLANT À L'INTÉRIEUR DE LA CAGOULE

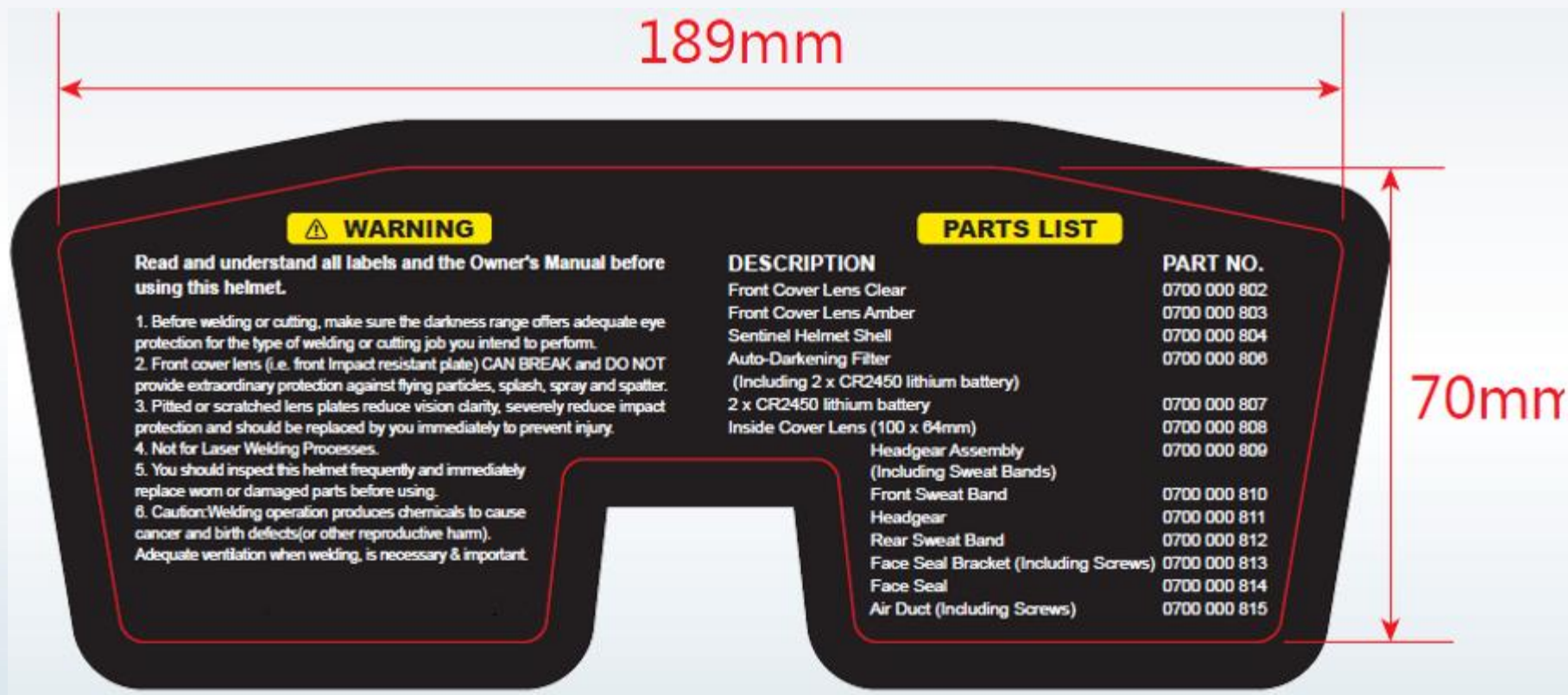

# CLASSE OPTIQUE CELLULE

## HIGH OPTICAL CLASS ADF

Optical Class	1/1/1/2
Viewing Area	100 mm x 60 mm
Size of Cartridge	133.00 mm x 114.00 mm x 9.00 mm
Lens Shade	DIN 5-8/9-13
Light State	DIN 3.0
Shade Control	Internal
Sensors	4
On/Off	Automatic
Power Supply	Solar cell + Battery replaceable (1*CR2450 lithium) Low battery alarm
Switch Time	0.04 ms at 55°C 0.075 ms at room temperature
Sensitivity Control	Low-high; adjustable with infinite dial knob
Delay Time (dark to light)	0.1 s ~ 1.0 s
Grind Mode	Yes
Low TIG Amps Rated	≥ 2 amps/DC; ≥ 2 amps/AC
Memory Setting	8 x preset memory function



# TECHNOLOGIE DE RESTITUTION D'IMAGE ET COULEUR

Clear View (no  
ADF)



**SENTINEL**  
(True Colour)

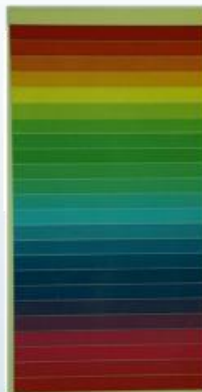

Traditional ADF



# INTRODUCTION D'UN ÉCRAN NUMÉRIQUE TACTILE

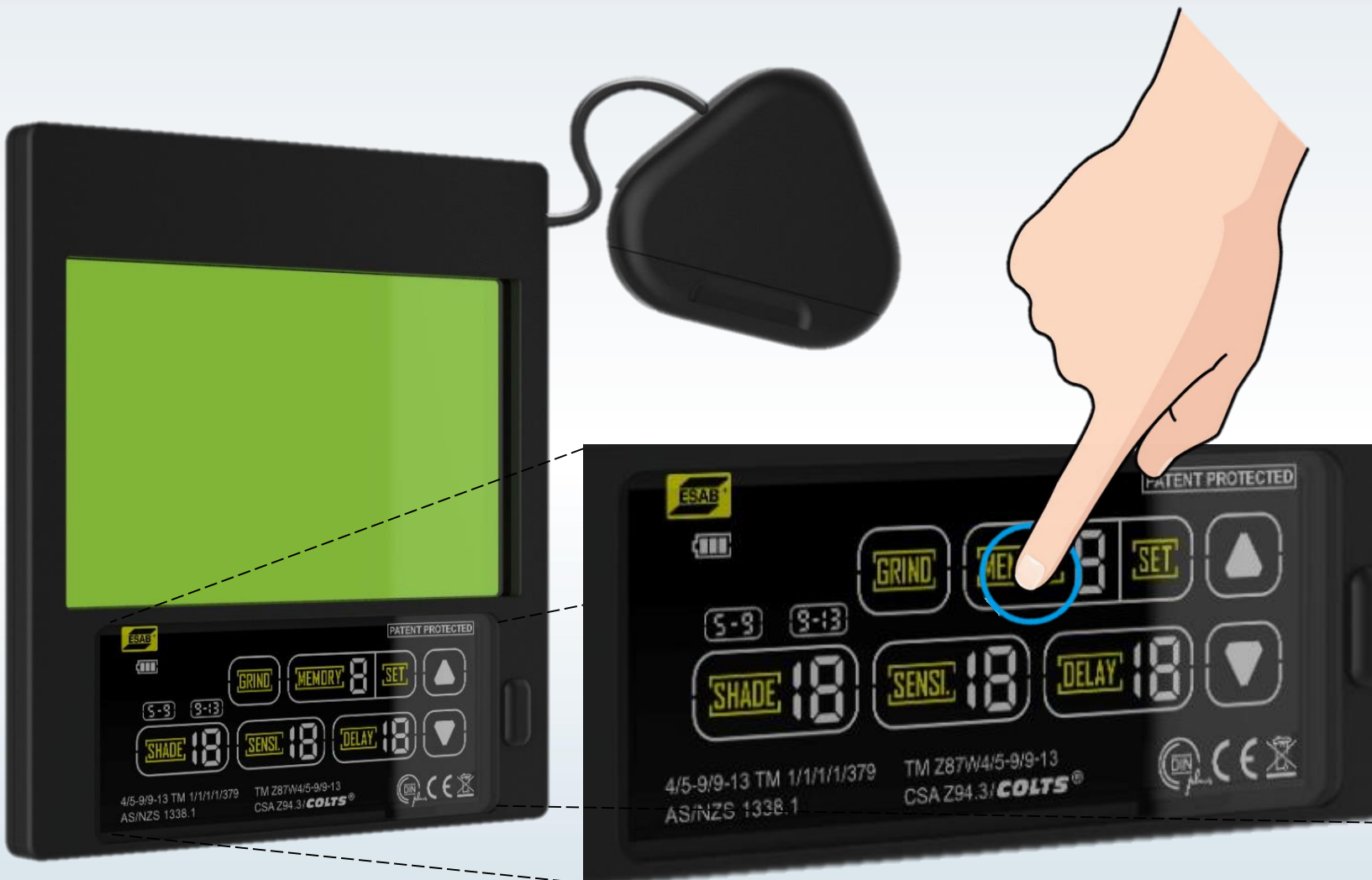



# FONCTIONNALITÉS DE BASE

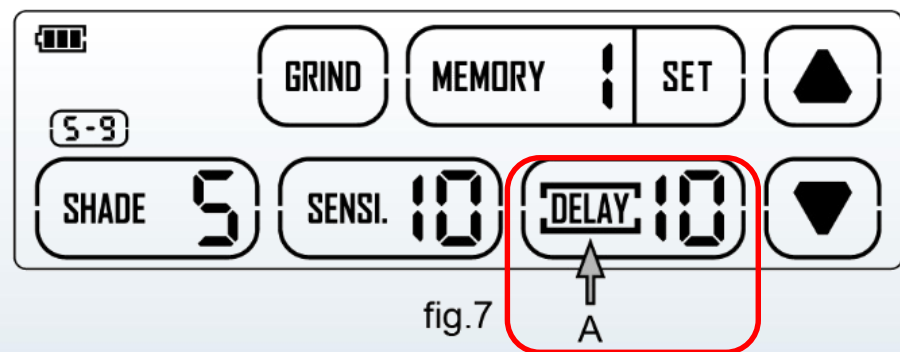
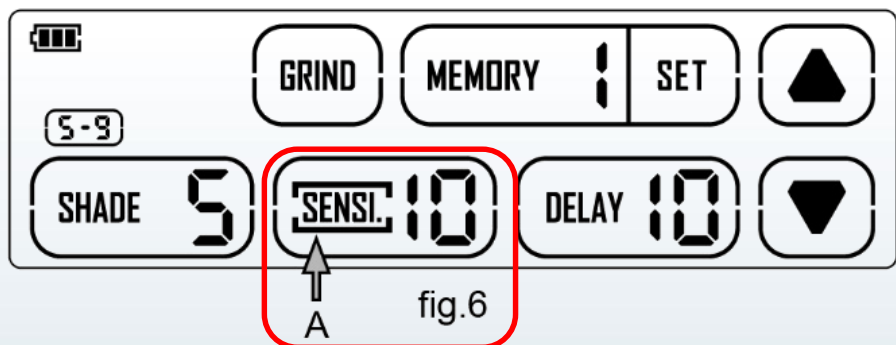
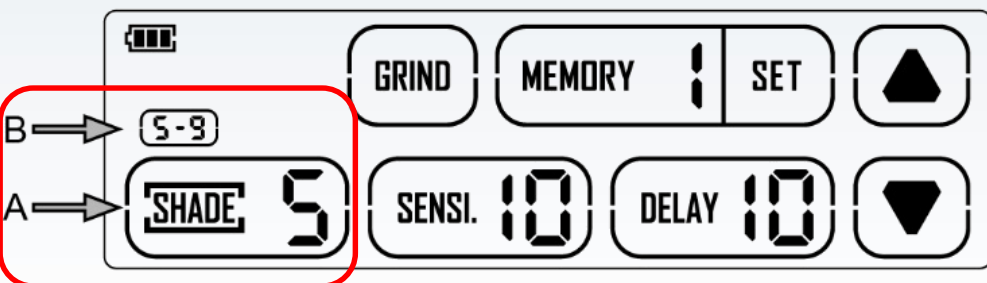

# ENREGISTRER LES RÉGLAGES EN MÉMOIRE

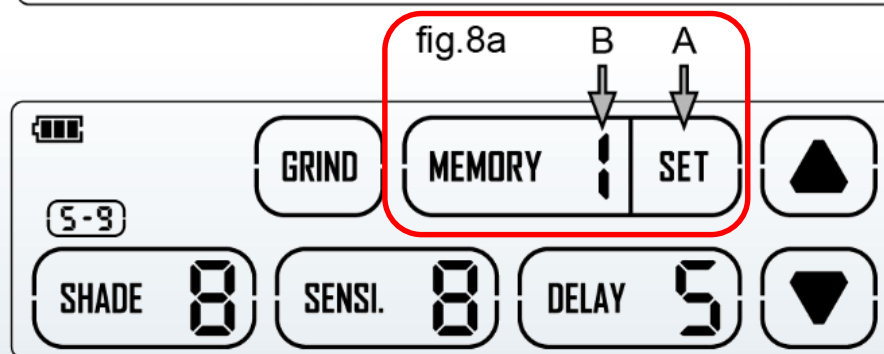
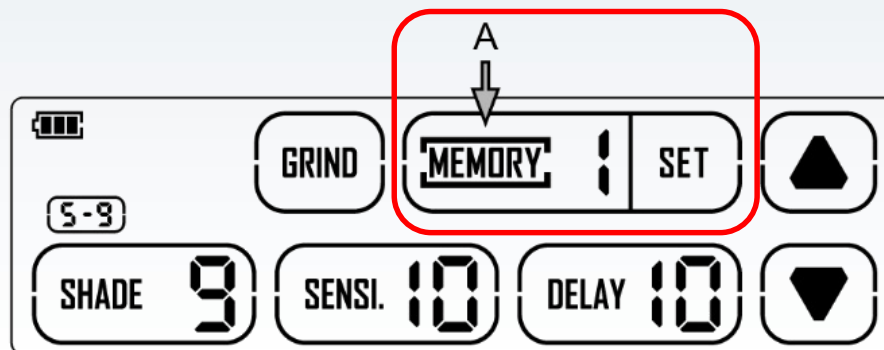

fig.8b

# ACTIVATION MODE MEULAGE



fig.4

- 2 possibilités d'activation
  - 1 x activation interne
  - 1 x activation externe
- *LED "GRIND" indique que la cagoule est en mode meulage*



fig.2b

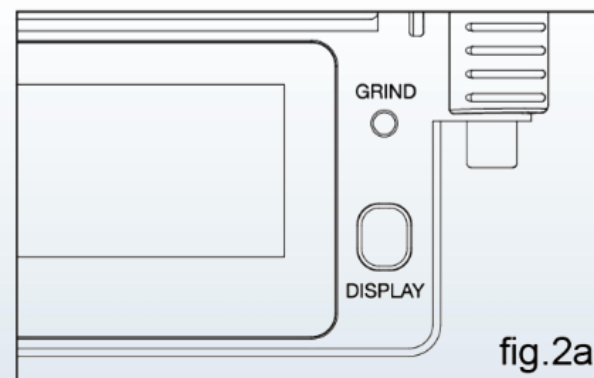
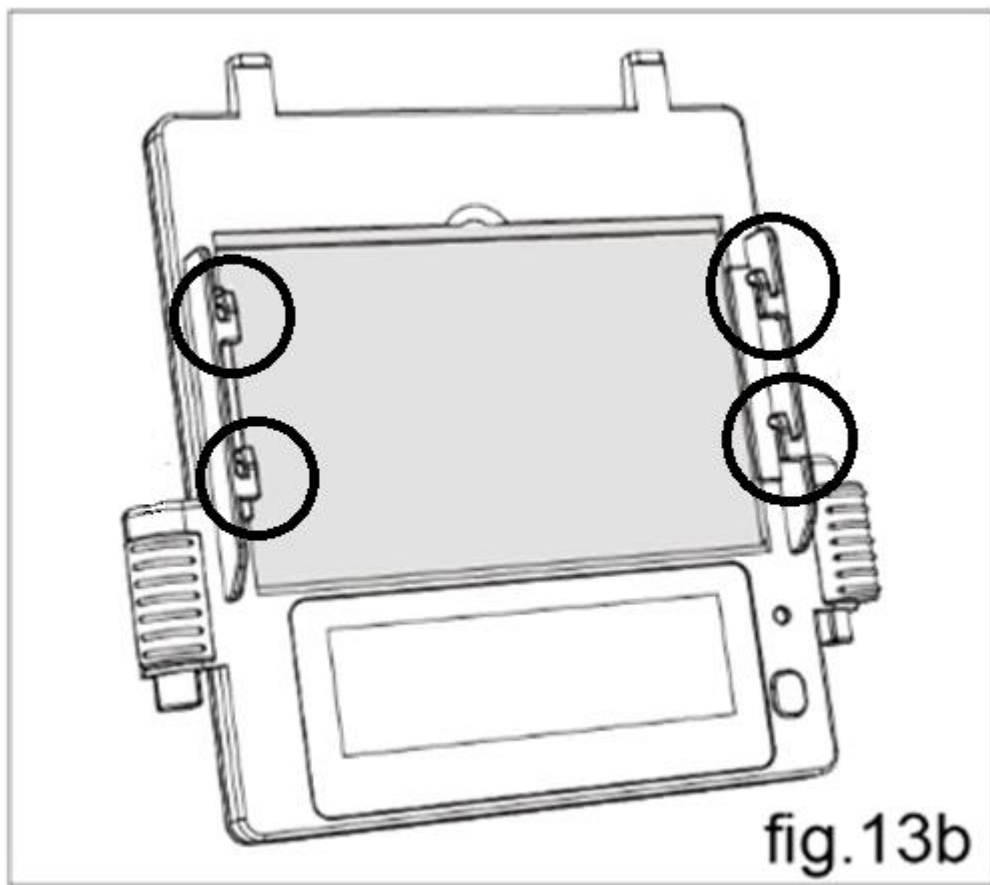
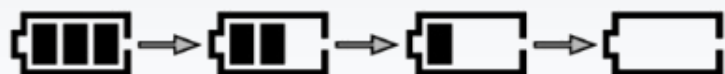

fig.2a

# INSTALLATION D'UN VERRE DIOPTRIE



# ALIMENTATION ET CONSOMMATION



- Indicateur batterie sur écran LED
- Testé + 2000h "temps d'arc"

fig.3

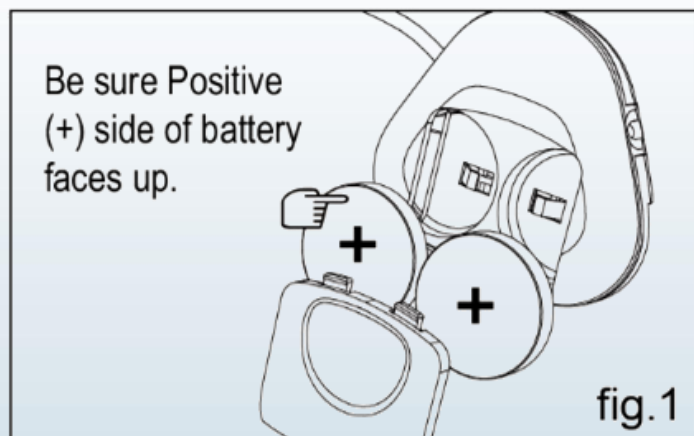

- 2 x batteries CR2450 Lithium ion remplaçable
- Localisé à l'intérieur de la cagoule

# ASSEMBLAGE DES PIECES DE RECHANGE ET USURE

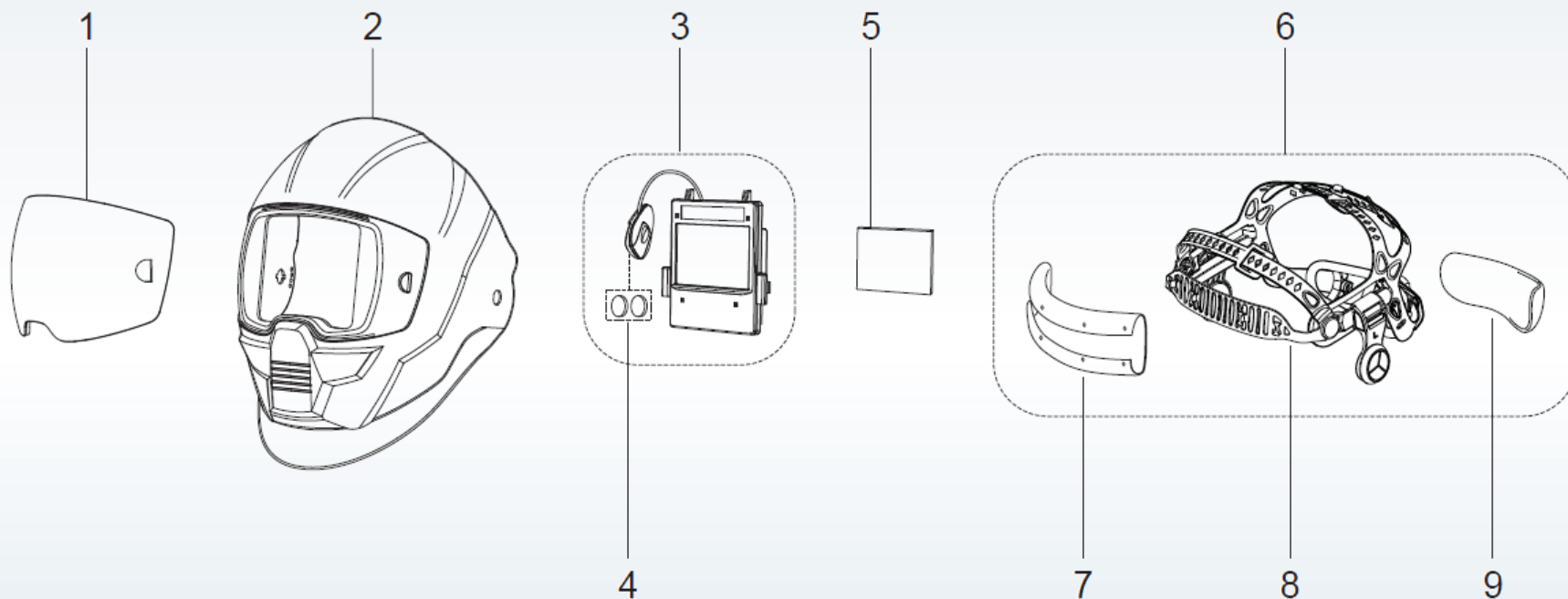



# SENTINEL: UNE CAGOULE HAUT DE GAMME AVEC DE NOMBREUSES FONCTIONNALITÉS ASTUCIEUSES



- ✓ Design révolutionnaire
- ✓ Soft touch, peinture mate
- ✓ Serre-tête "Halo" ergonomique
- ✓ Ecran de protection extérieur avec couche anti-rayure
- ✓ 100 x 60mm 1/1/1/2 – 5-13 ADF colour definition
- ✓ Bouton meulage activable à l'extérieur de la coque en appuyant pendant 2,5sec
- ✓ Mode meulage teinte 3.0
- ✓ 8 x mémoires
- ✓ Interface écran couleur tactile
- ✓ Nouveau système de conduit d'air (version ventilée)
- ✓ Nouveau système de connection de casque de chantier.



# SENTINEL™ A-50 AIR



# SENTINEL A50 AIR



- ✓ Tissu d'étanchéité de tête et visage très léger
- ✓ Niveau de serrage du tissu est facilement ajustable

# ENTRÉE D'AIR LATÉRALE



- ✓ Entrée latérale: libère plus de place
- ✓ Arrivée d'air au niveau de la bouche pour bien disperser l'air à l'intérieur de la cagoule
- ✓ Elimine l'effet des yeux sèches

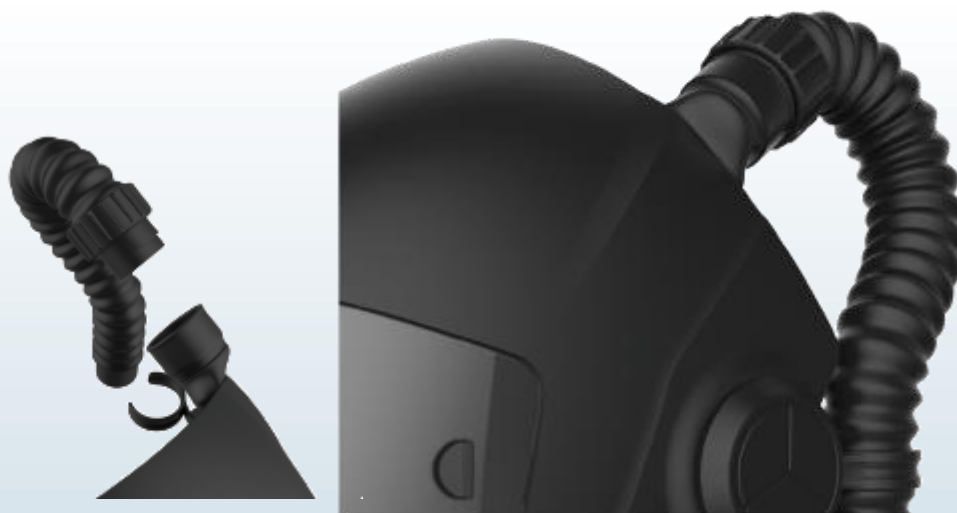

# COMMENT CHANGER LE TISSU D'ÉTANCHÉITÉ

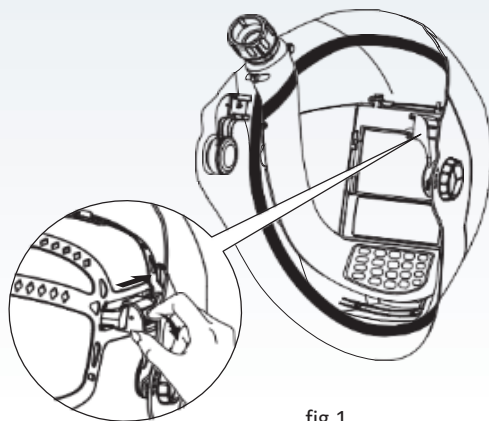

fig.1

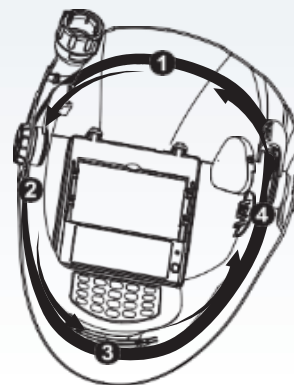
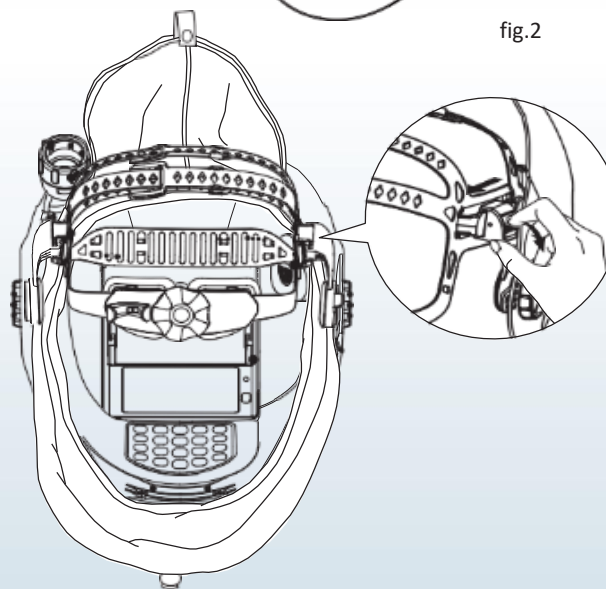

fig.2



# KIT RETROFIT DISPONIBLE

## 0700 000 799



Kit Retrofit = une  
SENTINEL A50 Air sans  
cellule optoélectronique



# CONTENU DE LIVRAISON DE LA CAGOULE

1. Cagoule SENTINEL A50 (air) avec écran extérieur ambre
2. 3 x Ecrans extérieur claires
3. 2 x CR2450 batteries installées dans la cagoule
4. Bandana ESAB
5. Sac de rangement SENTINEL
6. Manuel en 28 langues



## **2. GAMME DE CAGOULES DE SOUDAGE F&G**

# F20 & F20 AIR

Cagoule de soudage avec verre de protection teinte fixe



- Version préparée pour fresh air ou classique
- Disponible avec des écrans de 60x110 ou 90x110
- Version air compatible avec ECO Air et Aristo Air
- Équipé de verres teinte 10
- Verres de soudage disponible de teinte 9 à 13
- Standardisation: même serre-tête que la Warrior-Tech ou Warrior Tech pour air
- Remplace la gamme Albatross 1000 et Albatross 1000 pour air

# G30 & G30 AIR



- Version préparée pour fresh air ou classique
- Version air compatible avec ECO Air et Aristo Air
- Standardisation: même serre-tête que la Warrior-Tech ou Warrior Tech pour air
- Deux versions disponibles: teinte 10 et 11
- Visières claires: 2 – 3 – 5
- Visières extérieures: 5 – 8 – 10

NOTE: comment calculer la teinte finale

$$3 + 8 = 11 - 1 = \text{TEINTE } 10$$

$$2 + 10 = 12 - 1 = \text{TEINTE } 11$$

# G40 & G40 AIR / G50 & G50 AIR



- Versions avec teinte fixe (G40) ou cellule optoélectronique (G50)
- Version préparée pour fresh air ou classique
- Version air compatible avec ECO Air et Aristo Air
- Standardisation: même serre-tête que la Warrior-Tech ou Warrior Tech pour air
- Deux versions disponibles: teinte 10 et automatique (9-13, même cellule que la Warrior Tech mais sans la commande extérieure)
- Version passive: deux versions: 60x110mm et 90x110mm
- Version automatique: 97 x 47 mm

# MARQUAGE MASQUES DE SOUDAGE



Sentinel - A50 (Automatique)



G50 (Grinding)



G40 (Grinding)



G30 (Grinding)



F20 (Flip-up)





# **3. CAGOULE DE SOUDAGE WARRIOR TECH**



# WARRIOR™ TECH



WELD  
**WARRIOR™**



# WARRIOR™ TECH: NOUVELLE CELLULE



**Classe optique:**

**Champ de vision:**

**Temps de commutation:**

**Niveau d'assombrissement :**

**Nombre de Capteurs:**

**Delai:**

**Sensibilité:**

**Norme Impact (coque):**

**Norme cellule:**

**WARRIOR™ Tech**

1/2/1/2

98 x 48mm

0.3ms

9-13 external

4

Internal

Internal

EN 166

EN 379

# WARRIOR™ TECH PRÉPARÉE POUR AIR

 **WARRIOR™** Tech préparée pour Air

noire      **0700 000 405**  
jaune      **0700 000 406**



 Certifié avec système respiratoire « PAPR »



# WARRIOR™ TECH: LENTILLES GROSSISSANTES

références

1,0      0700 000 084

1,5      0700 000 085

2,0      0700 000 086

2,5      0700 000 087

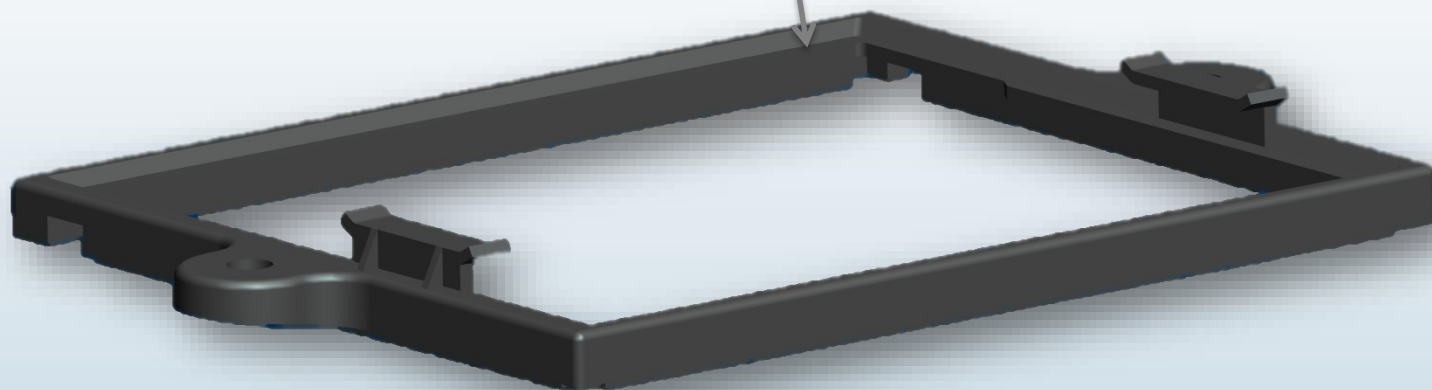



# WARRIOR™ TECH



 2 ans de garantie

## Fonctions et avantages pour le soudeur...



### UNE MEILLEURE PERFORMANCE

Quatre capteurs d'arc pour une plus grande réactivité et une plus grande couverture

Des performances optimales pour la plupart des soudages de fabrication et soudages en position



### COMMANDE DE SENSIBILITÉ

Fonction réglable utile lorsque l'on soude à faible intensité (TIG) pour une meilleure réaction à la lumière plus sombre de l'arc



### VASTE CHAMP DE VISION

98 mm x 48 mm (3,85" x 1,88")

Donne un plus large champ de vision et augmente la perception de l'espace.

Classe optique 1/2/1/2  
Niveau d'assombrissement 9 – 13



### COMMANDE DU RETOUR À L'ÉTAT CLAIR

Permet au soudeur de régler la durée pendant laquelle le verre reste sombre après l'arrêt de l'arc de soudage.

Un bref temps de retour à l'état clair permet de travailler plus rapidement pendant le pointage, mais un temps plus long est utile dans le soudage à haute intensité.

# **4. PAPR – SYSTÈME À ADDUCTION D’AIR**



# LE “PAPR”... LES DÉTAILS



- ✓ Design compact, contrôlé par LED panel
- ✓ Débit d'air ajustable 180 - 210 l/min
- ✓ Léger ....1kg
- ✓ Autonomie jusqu'à 9h au débit maxi (Panasonic Li-Ion cell)
- ✓ Chargeur adapté à d'autres pays (UK, US etc...)
- ✓ Filtre P3 & pré filtre
- ✓ Alarme pour filtre saturé
- ✓ Alarme batterie faible
- ✓ Ceinture améliorée avec bretelles

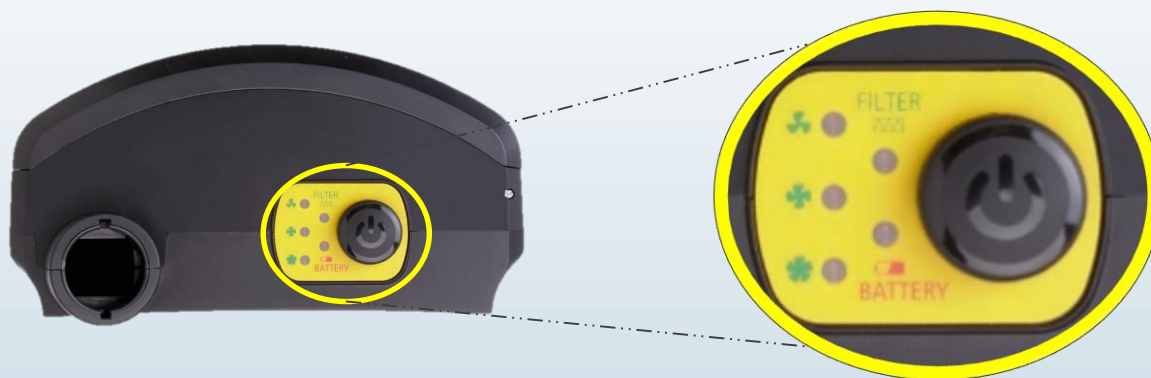

*Un seul bouton pour tout*



# EFFICACITÉ DE LA BATTERIE PANASONIC

- Addressing the customer needs for increased working times.



- Batterie très compacte et légère, qui a une autonomie de 8h avec filtre P3 et préfiltre neuf. Les interventions en milieu poussiéreux et contaminé peuvent sensiblement réduire son autonomie.
- Avec une batterie HD l'autonomie sera de: 14h au débit maxi et de 21h au débit mini



# ESAB PAPER FILTERS

## Technical Data

<b>Filter*</b>	<b>P3 Filter - 0700 002 309</b>
<b>Type Description</b>	<p>Each Filter is supplied in a sealed poly bag complete with a ESAB header card.</p> <p>The filter is supplied with a sealing gasket and labelled product code, storage condition, EN standard and shelf life.</p> <p>The filter is ready for immediate use once removed from poly bag.</p> <p>The particulate filtering media is pleated into a curved shape which maximise the filtering surface area.</p>
<b>Technical Specification</b>	<p>Filtering efficiency = 99.97%</p> <p>Filtering media = Glass Micro Fibres.</p> <p>Weight = 8.6grms</p> <p>Frame colour = white</p> <p>Frame material ABS (Acrylonitrile-Butadiene-Styrene).</p> <p>Gasket material = Polyurethane</p> <p>Approved to EN 12941 TH2P/TH3P</p>



**Filtre ESAB**  
Superficie du filtre **2900cm<sup>2</sup>**



**Filter\***

**Type Description**

**Pre Filter - 0700 002 310**

Pre-filters are supplied in packs of 5 sealed in a poly bag complete with an ESAB header card.

Pre-filters are ready for immediate use.

A pre-filter is positioned in front of a main filter and will increase the operational life of the main filter.

**Technical Specification**

Filtering media = Polyester matting.

Colour = white

Weight = 1.5 grms each

Dimensions = 190x 95 x1mm

Approved to EN 12941



# RÉFÉRENCES



## Ordering Information

Description	Part Number
PAPR with Standard Hose 850 mm (33.5 in)	0700002300
PAPR with Long Hose 1000 mm (39.4 in)	0700002301

*PAPR unit delivered with Motor unit, Battery, Intelligent charger, P3 filter + Pre filter, Waist belt, Hose and proban hose cover.*

## Wear & Spare Parts

Description	Part Number
1 Proban Hose Cover 1000 mm (39.4 in)	0700002303
1 Proban Hose Cover 850 mm (33.5 in)	0700002304
2 Air Hose Standard 850 mm (33.5 in)	0700002305
2 Air Hose Long 1000 mm (39.4 in)	0700002306
3 Comfort Pad Incl. Waist Belt	0700002307
4 Motor Unit	0700002308
5 P3 filter	0700002309
6 Pre-filter Pk 5	0700002310
7 Intelligent Charger	0700002311
8 Battery	0700002312
8 Battery HD	0700002313
Kit Bag (empty)	0700002315
Waist Belt Shoulder Harness	0700002316

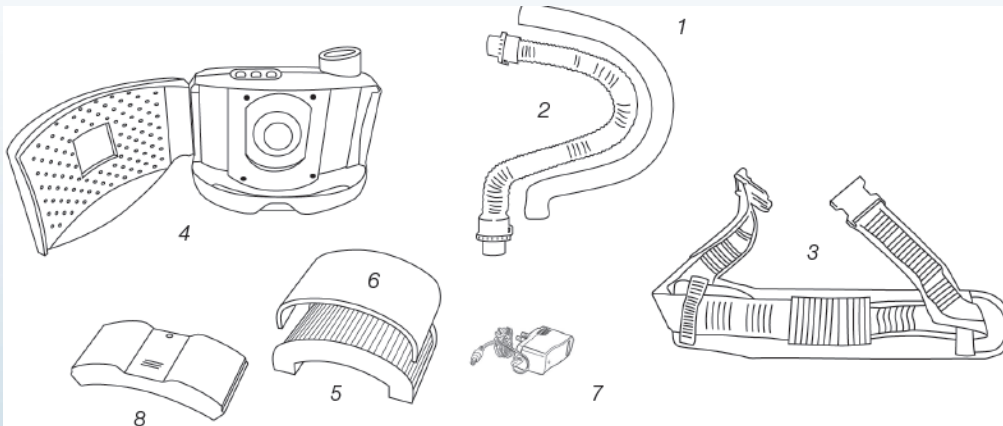

# CAGOULES COMPATIBLES.

Sentinel A50, Warrior Tech, G50, G40, G30, F20





**MERCI**



**QUESTIONS?**





[esab.com](http://esab.com)

